



Model DV-100

Size 4" X 4"

Standard Features

- Hot Dip Galvanized Trailers and Skids
 - Radiator Enclosure
 - Battery Box
 - Wheels
- Zinc Plated Jacks
- Emission Certified Engines
 - John Deere and Perkins
- DOT LED lights (optional)
- Electric Brakes with Safety breakaway
- Locking Battery Box

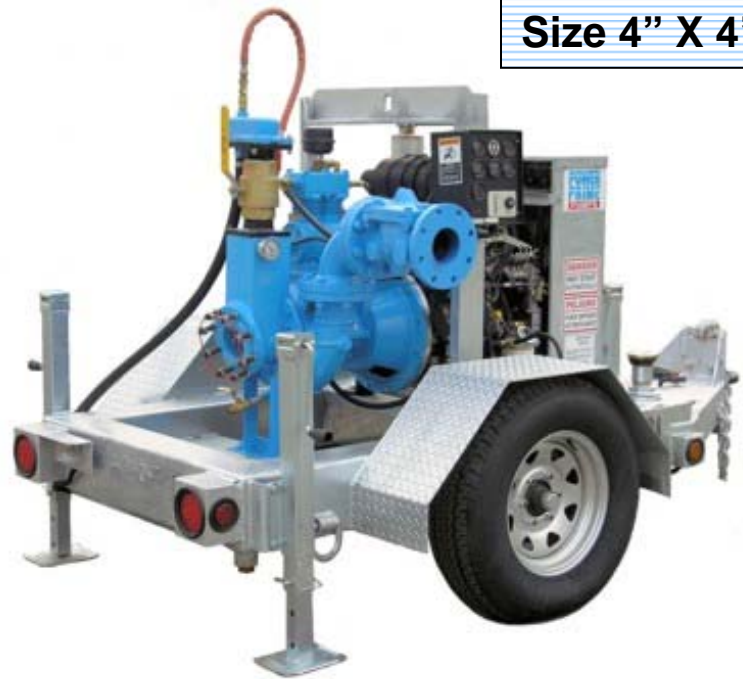

Pump Features

- Solids-handling capabilities to 1-3/4" diameter maximum
- Continuous self-priming
- Runs dry unattended
- Suction lift up to 28 ft.
- Skid- or trailer-mounted
- Auto-start-capable control panel
- Stainless Steel, CD4MCu and Chrome pump options

Technical

- SAE-mounted
- 12 volt, electric start with control panel
- Skid- or trailer-mounted with optional lifting bale
- 24-hour minimum capacity fuel tank
- Compressor/Venturi automatic priming system
- Electric drive option available
- Sound attenuated option available

Material Specifications

- Standard Build - Ductile Iron volute, Stainless Steel open impellers and replaceable wear plates
- Pump Shaft 431 Stainless Steel
- Mechanical Seal Solid silicon carbide mating faces Oil-bath lubrication for dry running
- Suction / discharge flanges ANSI 150# FF

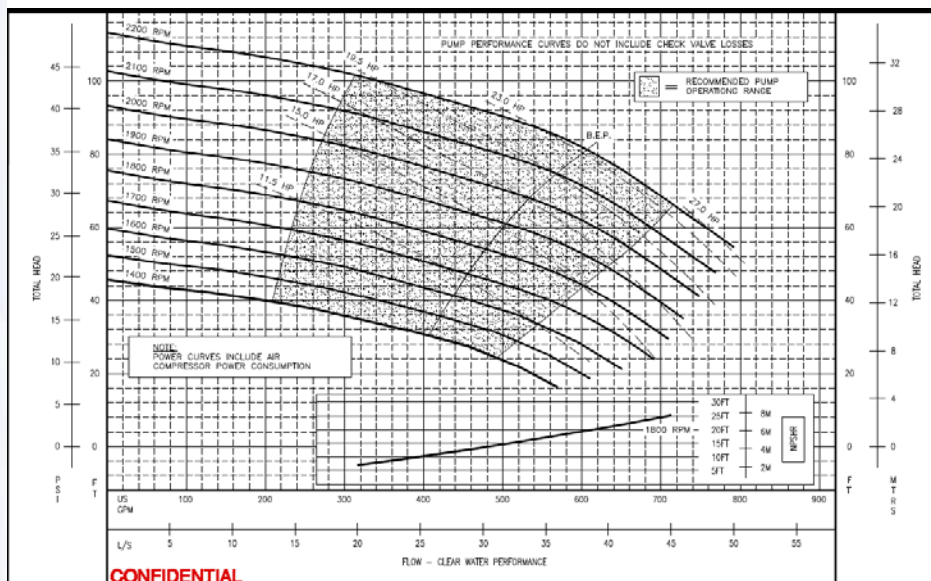

Rain for Rent
 P.O. Box 2248
 Bakersfield CA 93303
 800-742-7246
 661-393-1542
 FAX 661-393-1542
 www.rainforrent.com
 info@rainforrent.com

Rain for Rent is a registered trademark of Western Oilfields Supply Company. Features and Specifications are subject to change without notice.



DV-100 Technical Specifications

Production Curve

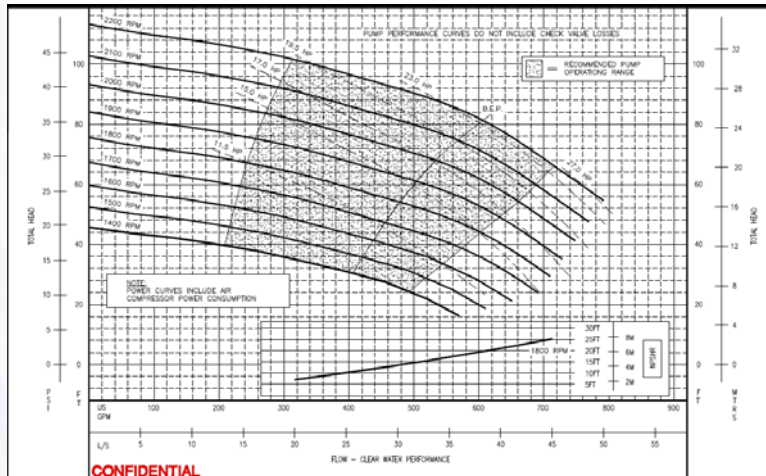

Performance Specs

STANDARD 3 VANE IMPELLER

Minimum Operating Speed:	1400 rpm
Maximum Operating Speed:	2200 rpm
Maximum Head:	115 ft.
Maximum Flow:	820 gpm

Design Details

Pump Designation:	DV-100
Pump Description:	Centrifugal end suction pump, single stage, volute type, fully open impeller
Solid Handling Size:	Up to 1.77inches (45mm)
Operating Temperature	MIN: -4°F (-20°C) - MAX: +212°F (+100°C)

Dimensions

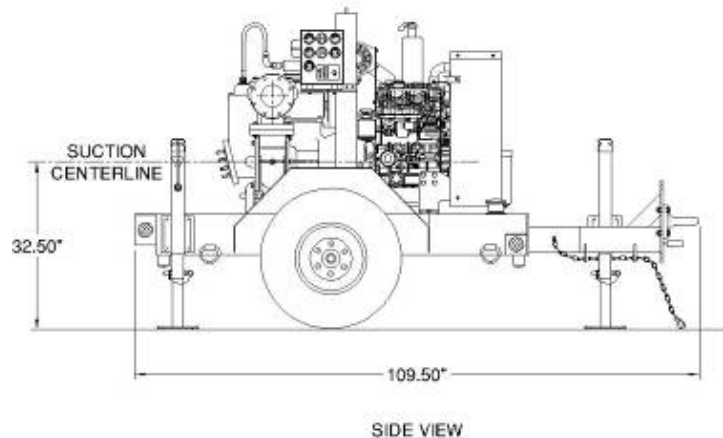
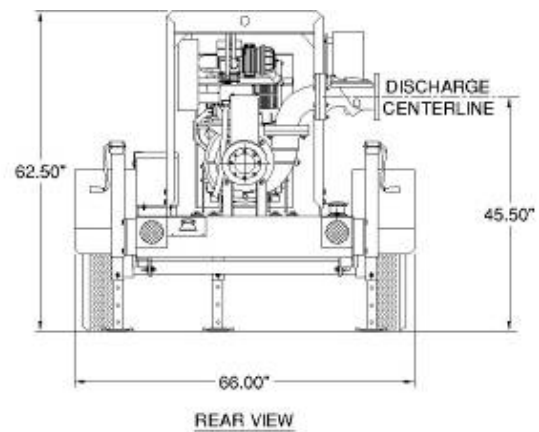

Rain for Rent
 P.O. Box 2248
 Bakersfield CA 93303
 800-742-7246
 661-399-9124
 FAX 661-393-1542
www.rainforrent.com
info@rainforrent.com

Rain for Rent is a registered trademark of Western Oilfields Supply Company. Features and Specifications are subject to change without notice.