



## Model DV-150

**Size 6" X 6"**

### Standard Features

- Hot Dip Galvanized Trailers and Skids
  - Radiator Enclosure
  - Battery Box
  - Wheels
- Zinc Plated Jacks
- Emissions Certified Engines
  - Perkins and John Deere
- DOT LED lights
- Electric Brakes with Safety breakaway
- Locking Battery Box

### Pump Features

- Solids handling capabilities to 3.0" diameter maximum
- Continuous self priming
- Runs dry unattended
- Suction lift to 28'
- Skid or trailer mounted
- Stainless Steel and CD4MCU\* Pump Options



### Technical

- SAE-mounted
- 12 volt, electric start with control panel
- Skid- or trailer-mounted with optional lifting bale
- 24-hour minimum capacity fuel tank
- Compressor/Venturi automatic priming system
- Electric drive option available
- Sound attenuated option available

### Material Specifications

- Standard build - Ductile Iron volute, Stainless Steel open impellers and replaceable wear plates
- Pump shaft  
431 Stainless Steel
- Mechanical Seal  
Solid silicon carbide mating faces  
Oil-bath lubrication for dry running
- Suction / discharge flanges ANSI 150# F.

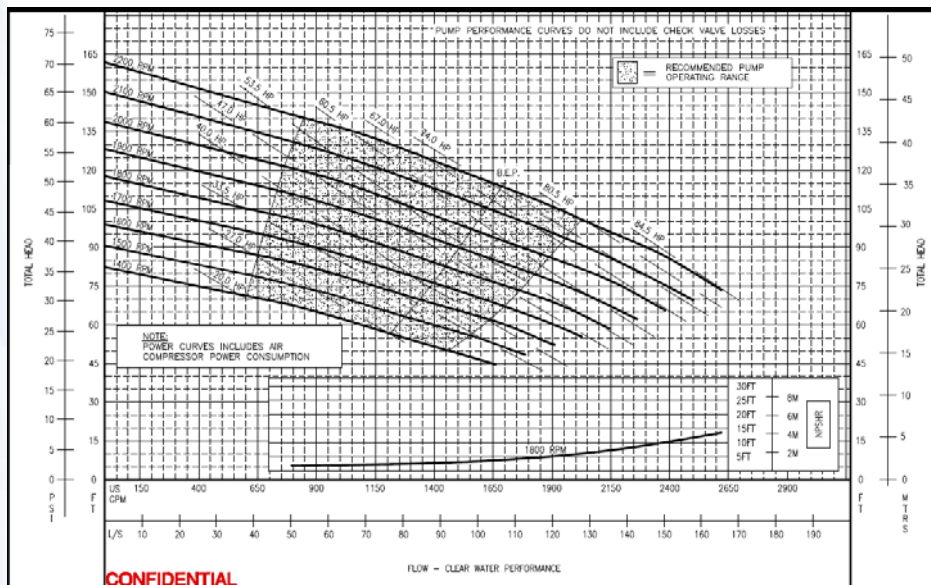

**Rain for Rent**  
 P.O. Box 2248  
 Bakersfield CA 93303  
 800-742-7246  
 661-393-1542  
 FAX 661-393-1542  
[www.rainforrent.com](http://www.rainforrent.com)  
[info@rainforrent.com](mailto:info@rainforrent.com)

Rain for Rent is a registered trademark of Western Oilfields Supply Company. Features and Specifications are subject to change without notice.



## DV-150 Technical Specifications

### Production Curve

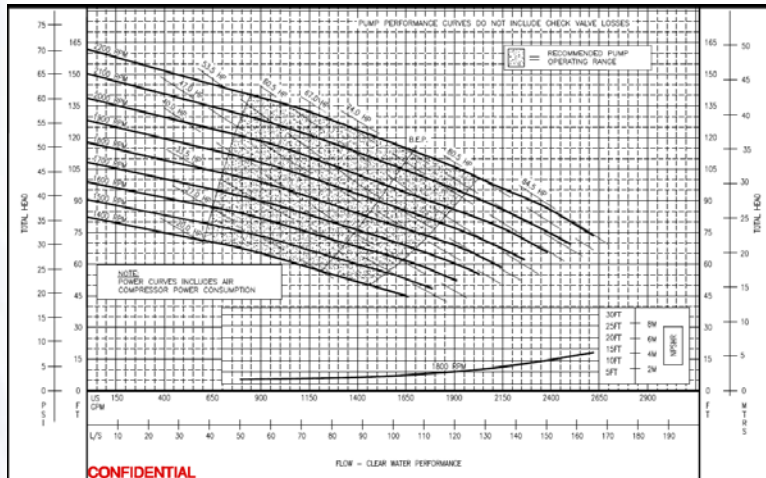

### Performance Specs

#### STANDARD 3 VANE IMPELLER

Minimum Operating Speed:	1400 rpm
Maximum Operating Speed:	2200 rpm
Maximum Head:	160 ft.
Maximum Flow:	2250 gpm

### Design Details

Pump Designation:	DV-150
Pump Description:	Centrifugal end suction pump, single stage, volute type, fully open impeller
Solid Handling Size:	Up to 3.0 inches (77mm)
Operating Temperature:	MIN: -4°F (-20°C) MAX: +212°F (+100°C)

### Dimensions

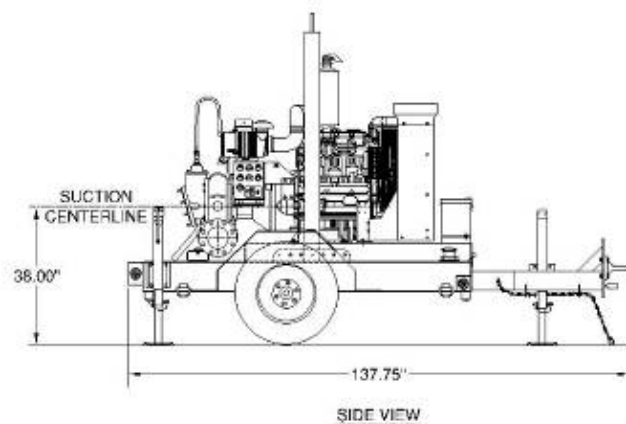
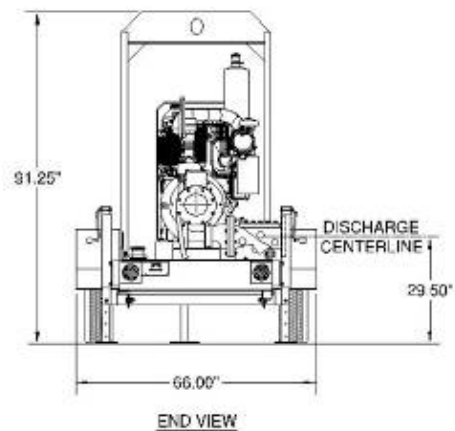

**Rain for Rent**  
 P.O. Box 2248  
 Bakersfield CA 93303  
 800-742-7246  
 661-399-9124  
 FAX 661-393-1542  
 www.rainforrent.com  
 info@rainforrent.com

Rain for Rent is a registered trademark of Western Oilfields Supply Company. Features and Specifications are subject to change without notice.