



Model DV-300i

Size 12" X 12"

Standard Features

- Hot Dip Galvanized Skids
 - Radiator Enclosure
 - Battery Box
- Emissions Certified Engines
 - Perkins, John Deere and Caterpillar
- Locking Battery Box

Pump Features

- Solids handling capabilities to 3.5" diameter maximum
- Continuous self priming
- Runs dry unattended
- Suction lift to 28ft.
- Skid-mounted



Technical

- Pedestal-mounted and flex-coupled to a diesel engine
- 12 volt, electric start with control panel
- Skid-mounted with lifting bale
- 250-gallon capacity integral fuel tank
- Skid plumbed for connection to external fuel tank
- Compressor/Venturi automatic priming system
- Electric drive option available
- Sound attenuated option available

Material Specifications

- Standard build – Ductile Iron volute, 316 Stainless Steel open impeller and replaceable wear plates
- Pump shaft 431 stainless steel
- Mechanical Seal Solid silicon carbide mating faces Oil-bath lubrication for dry running
- Suction / discharge flanges ANSI 150# FF.

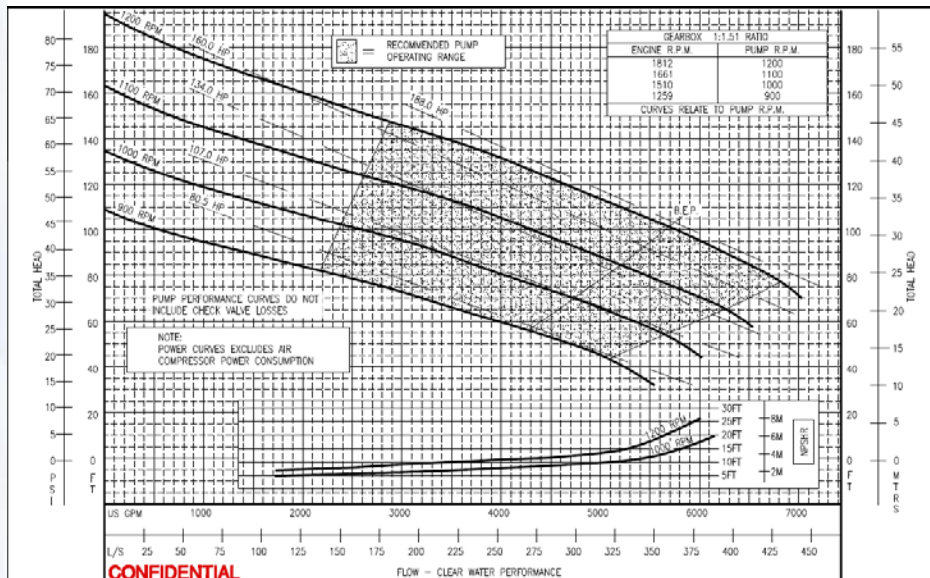

Rain for Rent
 P.O. Box 2248
 Bakersfield CA 93303
 800-742-7246
 661-393-1542
 FAX 661-393-1542
 www.rainforrent.com
 info@rainforrent.com

Rain for Rent is a registered trademark of Western Oilfields Supply Company. Features and Specifications are subject to change without notice.



DV-300i Technical Specifications

Production Curve

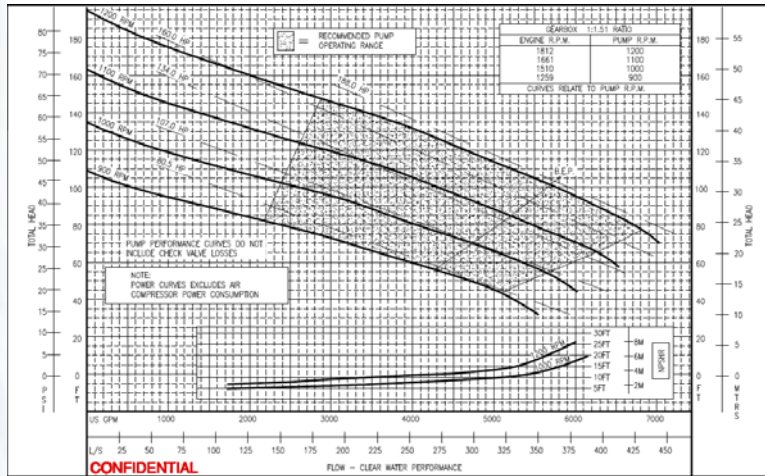

Performance Specs

STANDARD 3 VANE IMPELLER

Minimum Operating Speed:	900 rpm
Maximum Operating Speed:	1200 rpm
Maximum Head:	197 ft.
Maximum Flow:	6,900 gpm

Design Details

Pump Designation:	DV-300i
Pump Description:	Centrifugal end suction pump, single stage, volute type, 3 vane fully open impeller
Solid Handling Size:	3.5 inches (90mm)
Operating Temperature:	MIN: -4°F (-20°C) MAX: +176°F (+80°C)

Dimensions

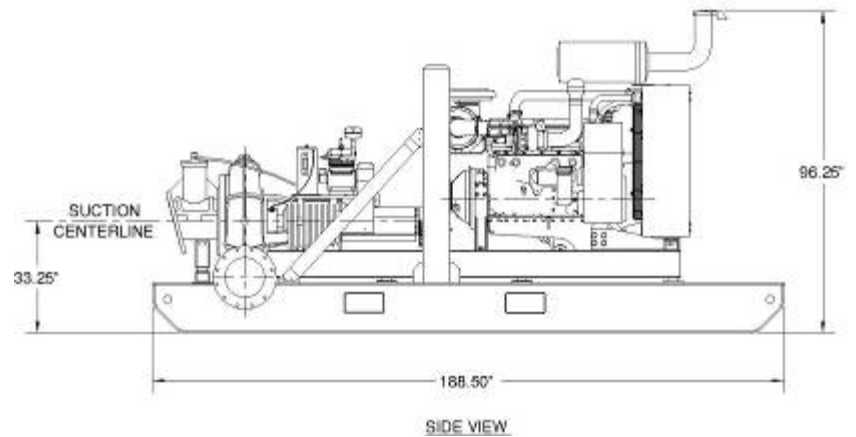
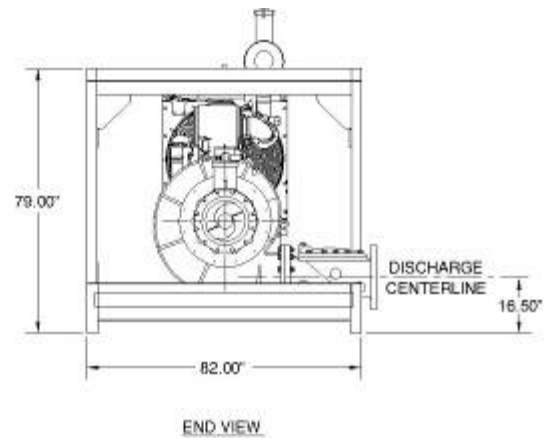

Rain for Rent
 P.O. Box 2248
 Bakersfield CA 93303
 800-742-7246
 661-399-9124
 FAX 661-393-1542
www.rainforrent.com
info@rainforrent.com

Rain for Rent is a registered trademark of Western Oilfields Supply Company. Features and Specifications are subject to change without notice.