



## Model DV-300i Electric

**Size 12" X 12"**

### Standard Features

- Hot Dip Galvanized Open Skids
- Fork Lift tubes
- Skid mounted with optional lifting bale
- Locking control panel
- Nu-T-Link compressor drive belt to allow easy belt replacement

### Pump Features

- Solids handling capabilities to 3.5" diameter maximum
- Continuous self priming
- Runs dry unattended
- Suction lift to 28ft.
- Skid mounted
- Stainless Steel, CD4MCu and Chrome pump options



### Technical

- Coupled to a 200hp 60Hz TEFC hostile duty dual voltage (240/460V) motor
- 460 volt soft start control panel equipped with motor protection
- UL Type 3L Control panel designed for outdoor duty
- Panel equipped with Terminal Blocks for 2 remote float switches (Low off, High on)
- 460/240V-120V fuse-protected control circuit transformer
- Compressor/Venturi automatic priming system

### Material Specifications

- Standard build – Ductile Iron volute, 316 Stainless Steel open impeller and replaceable wear plates.
- Pump shaft 431 stainless steel.
- Mechanical Seal Solid silicon carbide mating faces Oil-bath lubrication for dry running
- Suction / discharge flanges ANSI 150# FF.

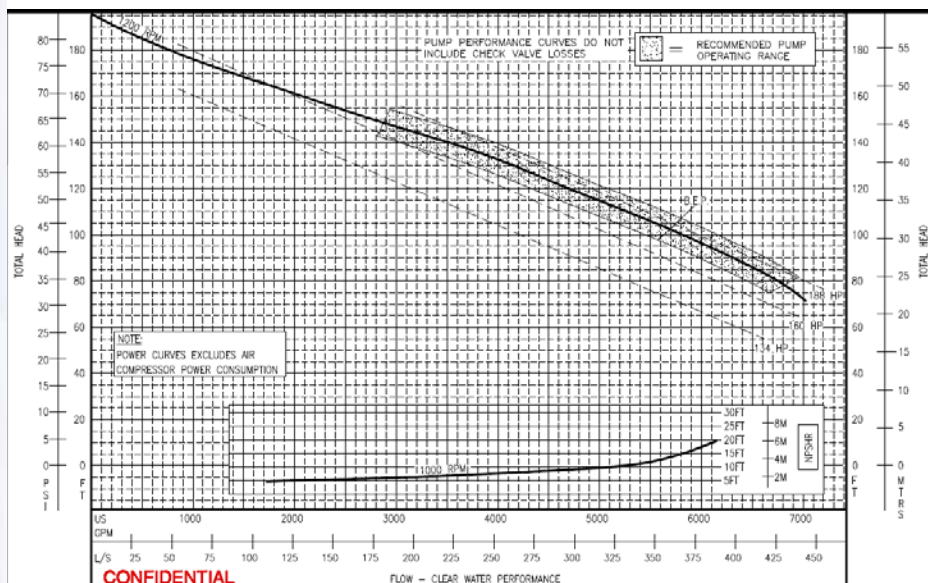

**Rain for Rent**  
 P.O. Box 2248  
 Bakersfield CA 93303  
 800-742-7246  
 661-393-1542  
 FAX 661-393-1542  
 www.rainforrent.com  
 info@rainforrent.com

Rain for Rent is a registered trademark of Western Oilfields Supply Company. Features and Specifications are subject to change without notice.



## DV-300i-E Technical Specifications

### Production Curve

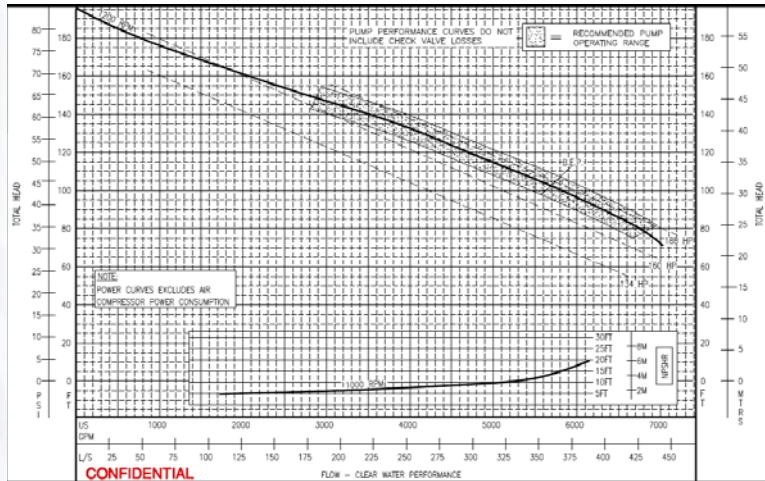

### Performance Specs

#### STANDARD 3 VANE OPEN IMPELLER

Maximum Operating Speed:	1185 rpm
Maximum Head:	197 ft.
Maximum Flow:	6,900 gpm

### Design Details

Pump Designation:	DV-300iE
Pump Description:	Centrifugal end suction pump, single stage, volute type, 3 vane fully open impeller
Solid Handling Size:	3.5 inches (90mm)
Operating Temperature	MIN: -4°F (-20°C) MAX: +176°F (+80°C)

### Dimensions

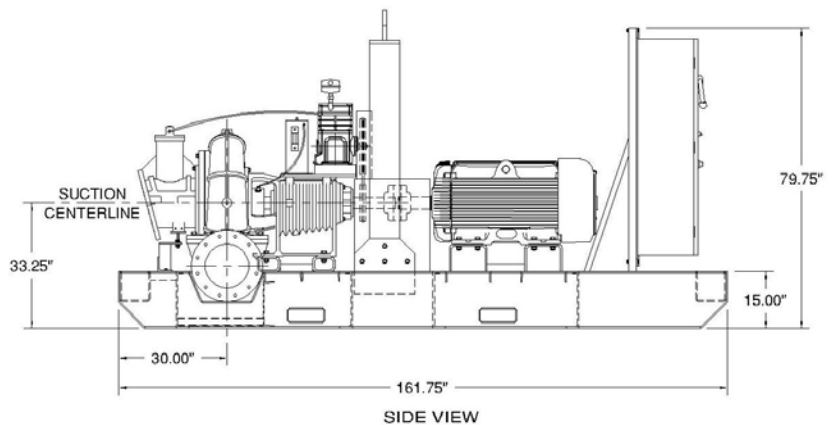
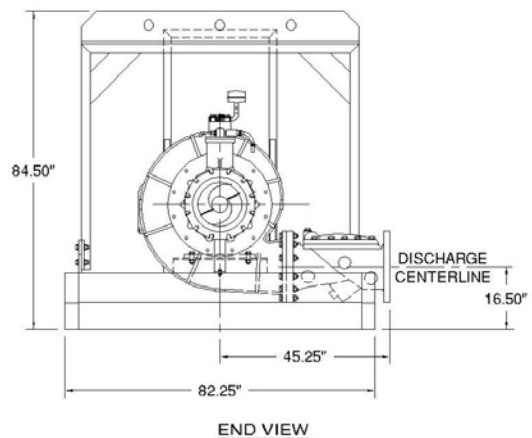

**Rain for Rent**  
 P.O. Box 2248  
 Bakersfield CA 93303  
 800-742-7246  
 661-399-9124  
 FAX 661-393-1542  
 www.rainforrent.com  
 info@rainforrent.com

Rain for Rent is a registered trademark of Western Oilfields Supply Company. Features and Specifications are subject to change without notice.